

TB17 v2

PanelPC 17" • INTEL Elkhart Lake • Encastrable et VESA

Processeur INTEL Elkhart Lake J6412

PanelPC 17" • Résolution 1280 x 1024

Dalle tactile P-CAP multipoints (résistif en option)

Châssis en aluminium • IP66 face avant

1 RS232 • 3 USB 3 • 3 USB 2

2 ports Ethernet INTEL I225 (2.5 GbE)

Alimentation 12V DC / 220 AC (option 12~24V DC)

Comptabilité Windows 11



Système	
Chipset	INTEL Elkhart Lake
Processeur	INTEL J6412
Proc. Vidéo	INTEL UHD Gen 10
Dalle LCD	17" • Résolution 1280 x 1024 • 250 nits
Dalle Tactile	Dalle capacitive PCAP 10 points (Dalle résistive en option)
Mémoire	32GB SODIMM DDR4 max
Stockage	M.2 2280 • 2.5"
Entrées / Sorties	2 HDMI 3 USB 3 • 3 USB 2 1 RS232 2 RJ45 1 mic-in / Line Out 1 DC Phoenix
Alimentation	AC 100~240V, 50Hz/60 Hz, DC 12V/4A Option 9V~36V DC

Communication	
Ethernet	2 RJ45 INTEL I225 (2.5 GbE)
WIFI	WiFi 802.11 a/b/g/n/ac (Option)
Bluetooth	BT4.2 (Option)
3G/4G (Option)	LTE FDD: B1/B3/B7/B8/B20/B28A WCDMA: B1/B2/B5/B8 GSM: B2/B3/B5/B8
RFID (Option)	13.56 GHz+125 Khz

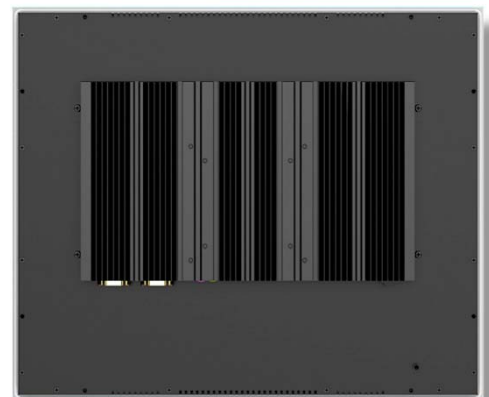

Environnement	
Temp. fonction.	0°C ~ 50°C
Temp. Stockage	-20°C ~ 70°C
Humidité	10%~90%
Durcissement	IP66 face avant Châssis métal + aluminium

Dimensions / Construction	
Matériau	Aluminium / Acier
Dimensions	386 x 323 x 56 mm Découpe: 376 x 313 mm
Poids	Environ 4.7 kg
Fixation	Encastrement (joint + vis) VESA 75 / 100

Dimensions

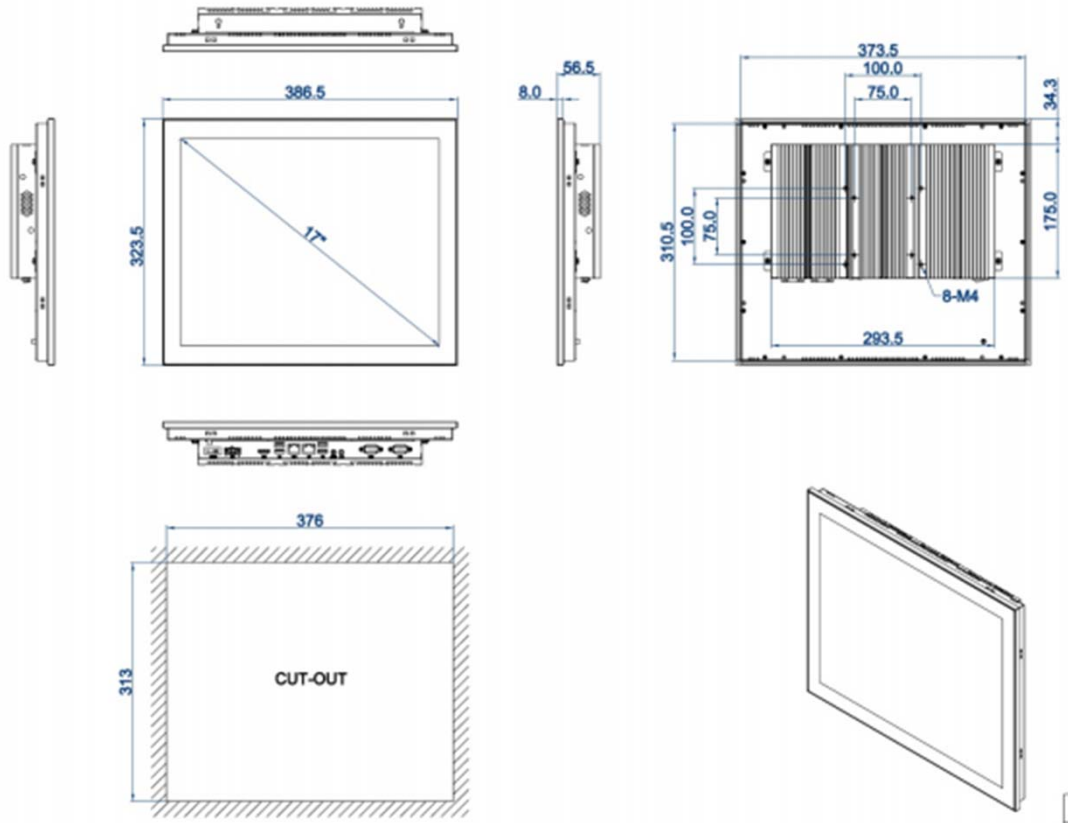

Options / Accessoires



Dalle résistive



Module 4G



Module Wifi



Fixation VESA

12-24V



12~24V DC