

## TC15v2

PanelPC 15" • Whiskey Lake • Core I3/I5/I7 • Encastrable et VESA

Chipset INTEL Whiskey Lake

Core I3-8145U • Core I5-8265U • Core I7-8565U

PanelPC 15" • Résolution 1024 x 768

Dalle tactile P-CAP multipoints ( résistif en option)

Châssis en aluminium • IP66 face avant

2 RS232 • 4 USB 3.0 • 2 USB 2.0

2 ports Ethernet INTEL I211AT

Alimentation 9~24V DC / 220 AC



Système	
Chipset	INTEL Whiskey Lake
Processeur	Core I3-8145U • Core I5-8265U Core I7-8565U
Proc. Vidéo	INTEL UHD620
Dalle LCD	15" • Résolution 1024 x 768 • 250 nits
Dalle Tactile	Dalle capacitive PCAP 10 points ( Dalle résistive en option)
Mémoire	16GB SODIMM DDR4 max
Stockage	mSATA • 2.5"
Entrées / Sorties	1 HDMI 4 USB 3.0 • 2USB 2.0 2 RS232 2 RJ45 1 mic-in / Line Out 1 DC Phoenix
Alimentation	AC 100~240V, 50Hz/60 Hz, DC 9~24V

Communication	
Ethernet	2 RJ45 INTEL I211AT
WIFI	WiFi 802.11 a/b/g/n/ac ( Option)
Bluetooth	BT4.2 ( Option)
3G/4G (Option)	LTE FDD: B1/B3/B7/B8/B20/B28A WCDMA: B1/B2/B5/B8 GSM: B2/B3/B5/B8
RFID ( Option)	13.56 GHz+125 Khz

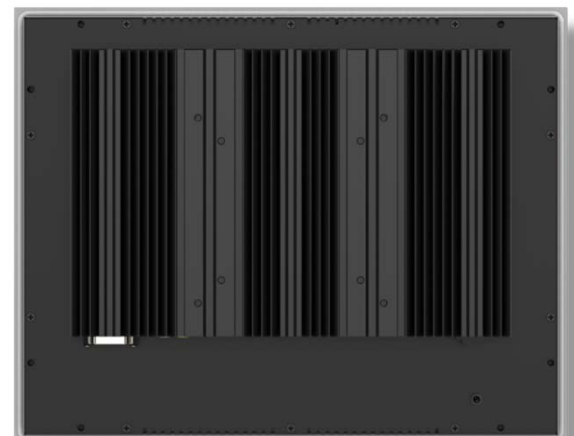

## Environnement

Temp. fonction.	-20°C ~ 60°C
Temp. Stockage	-20°C ~ 70°C
Humidité	10%~90%
Durcissement	IP66 face avant Châssis métal + aluminium

## Dimensions / Construction

Matériau	Aluminium / Acier
Dimensions	339 x 279 x 56 mm Découpe: 341 x 268 mm
Poids	Environ 3.5 kg
Fixation	Encastrement ( joint + vis) VESA 75 / 100

## Dimensions

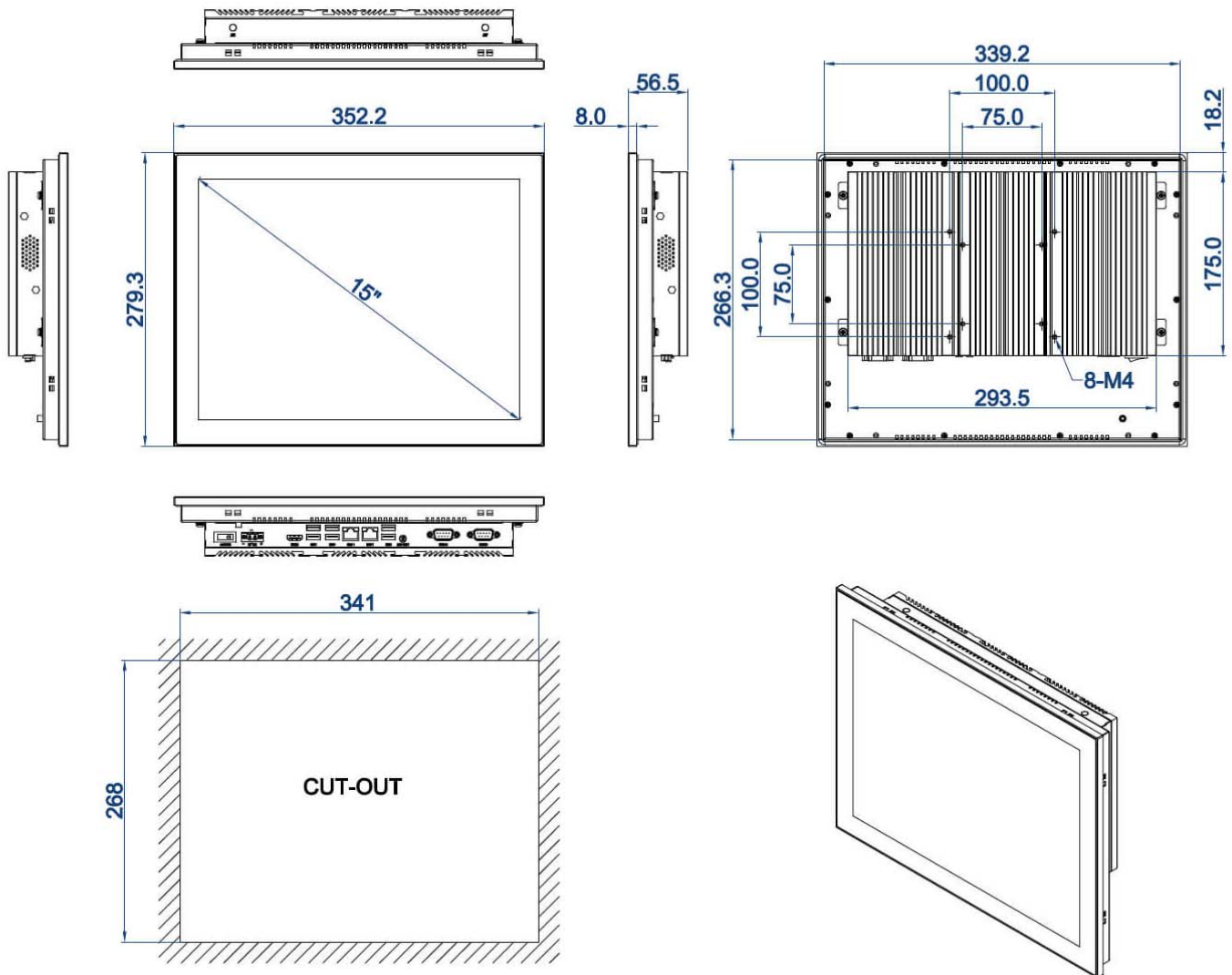

Dalle résistive



Module 4G



Module Wifi



Fixation VESA



Dalle plein jour